

1

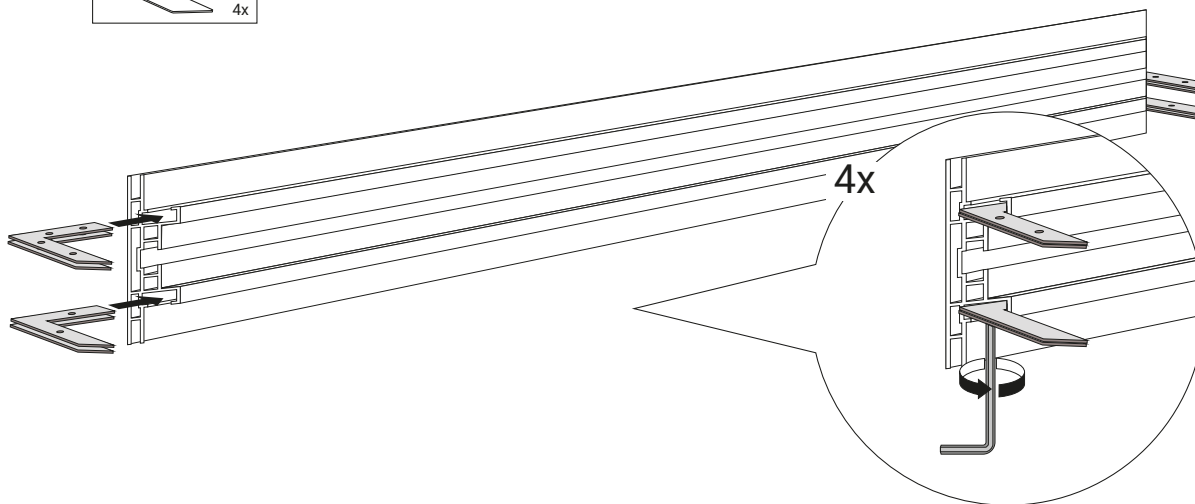

2

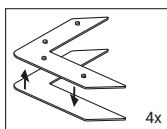
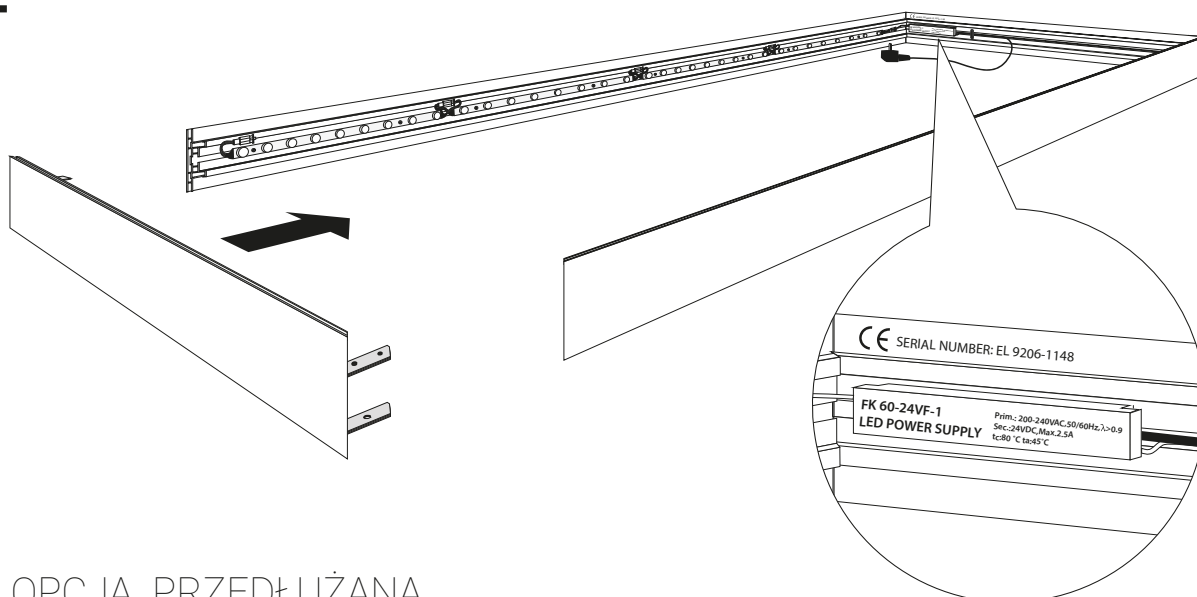

OPCJA PRZEDŁUŻANA  
OPTION FOR EXTENSION

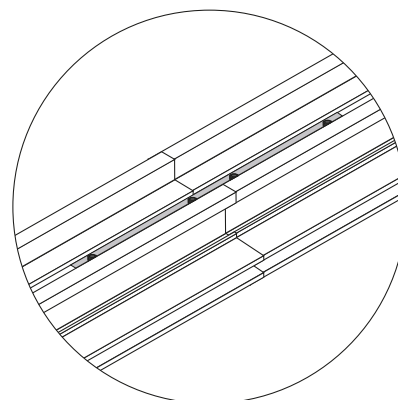
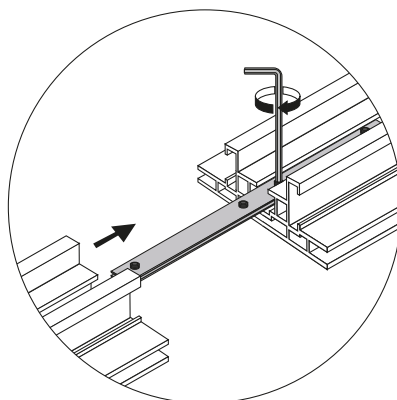
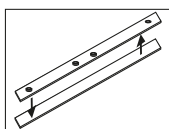

**3**

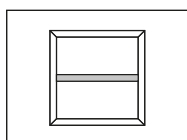
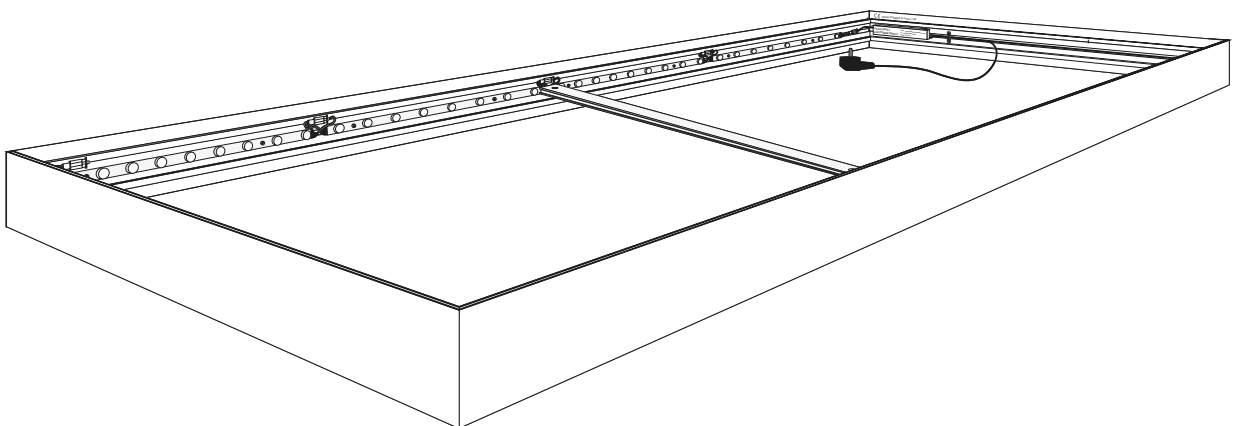
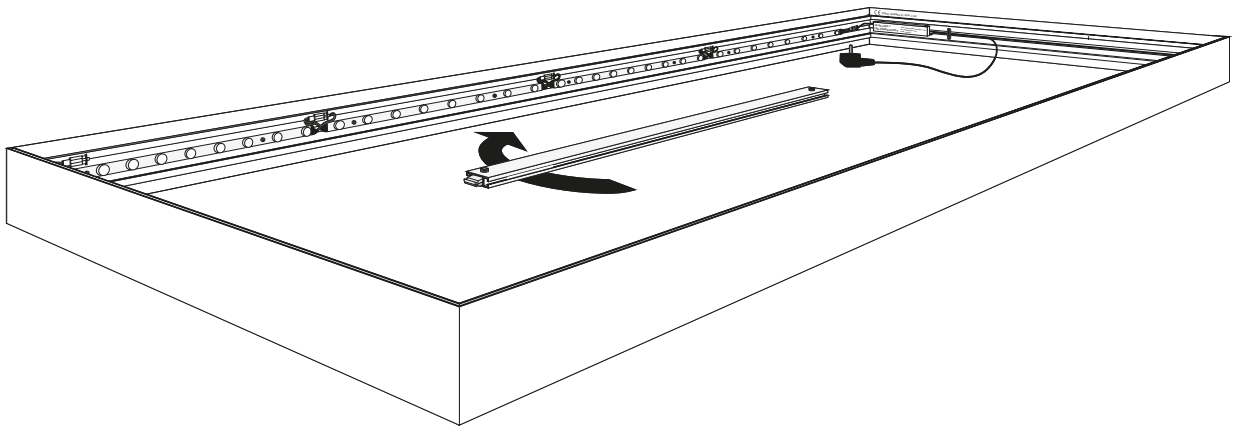
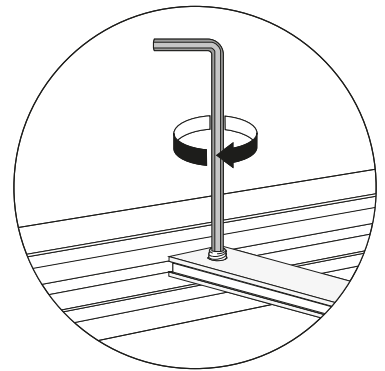
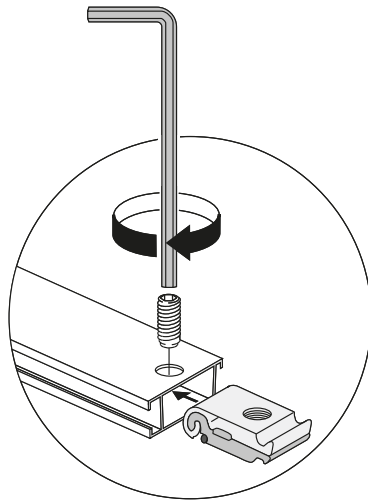
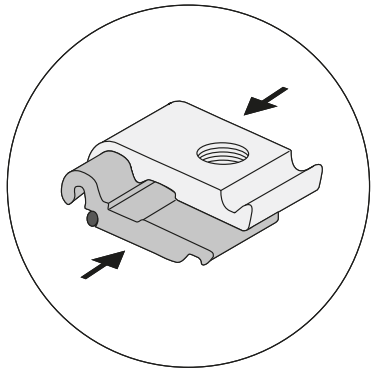

**Option 1**

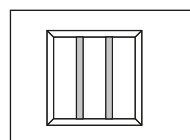

**Option 2**

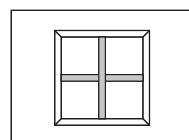

**Option 3**

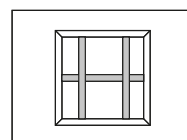

**Option 4**

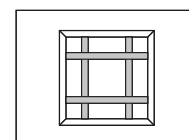

**Option 5**

OPCJA Z NOGAMI  
OPTION FOR FOOTPLATE

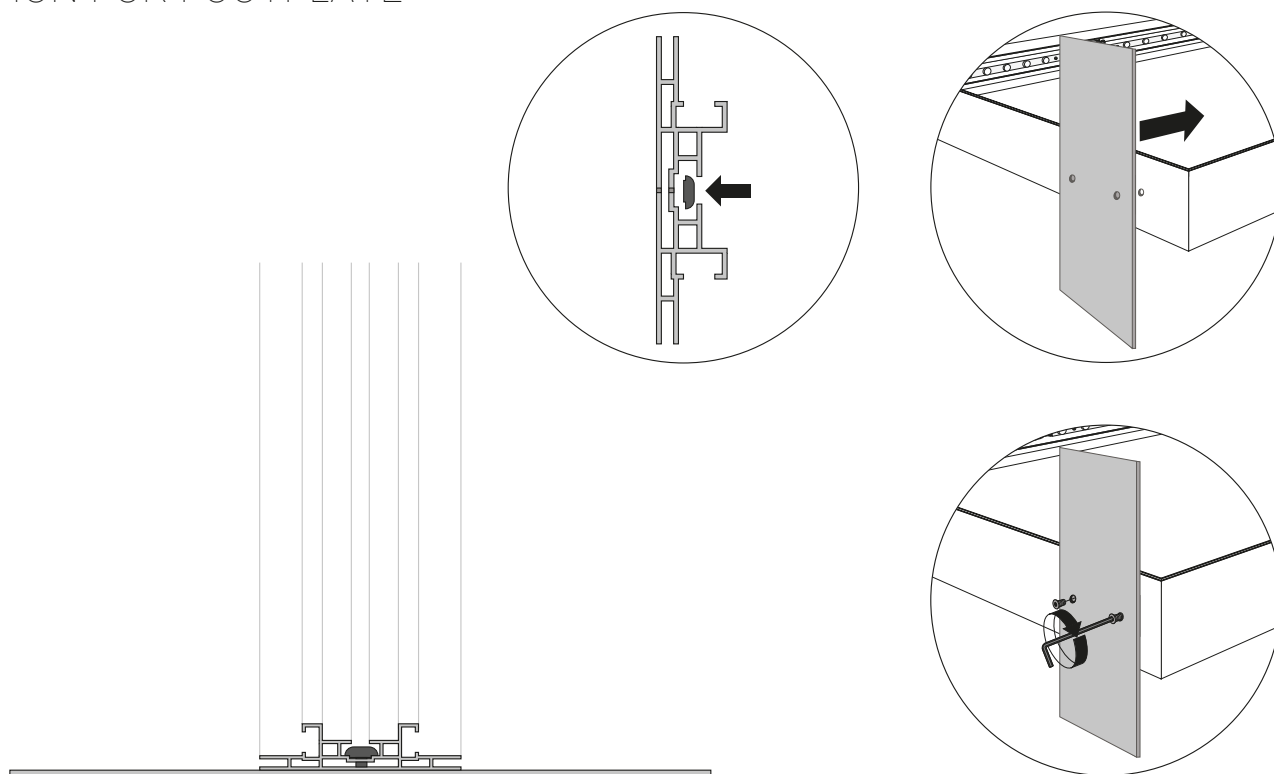

OPCJA MONTAŻ SUFITOWY  
OPTION CEILING MOUNT

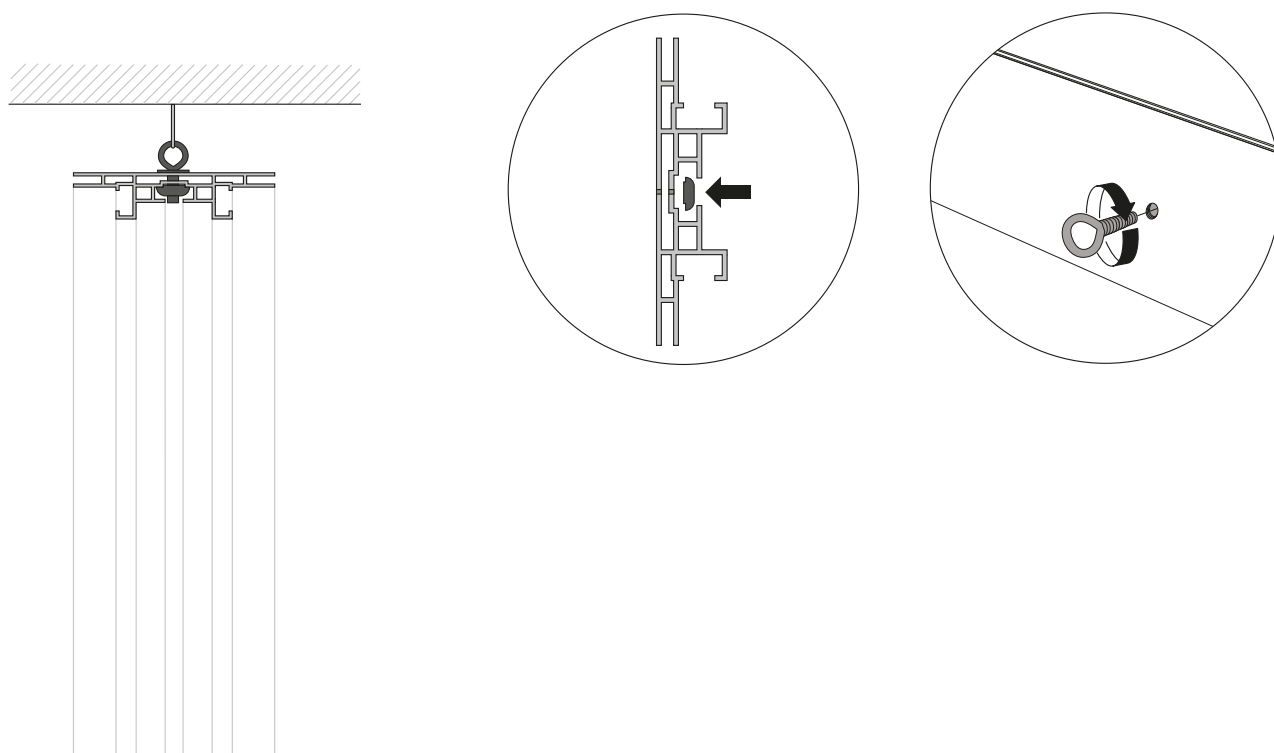

4

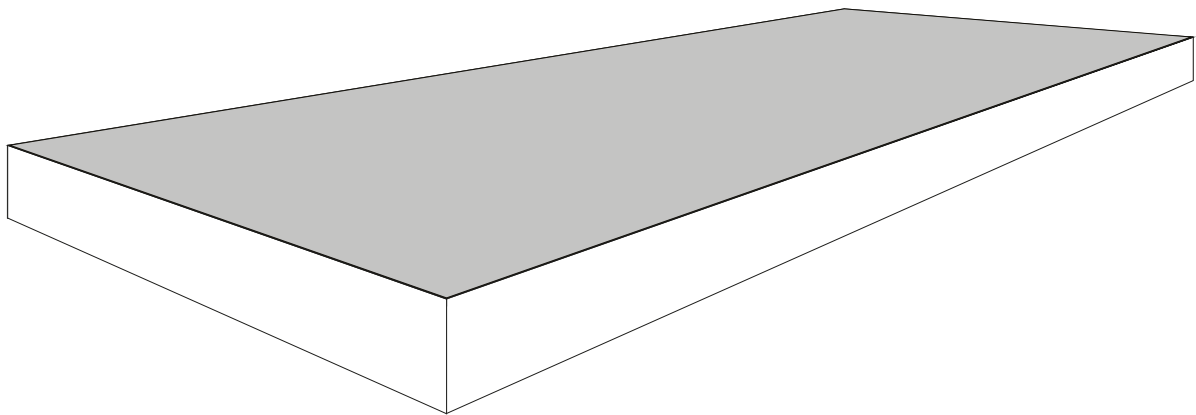
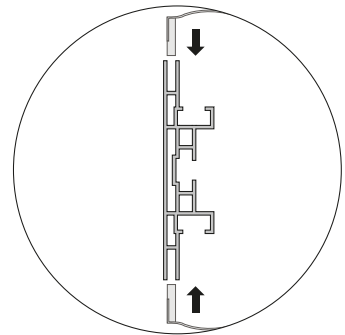
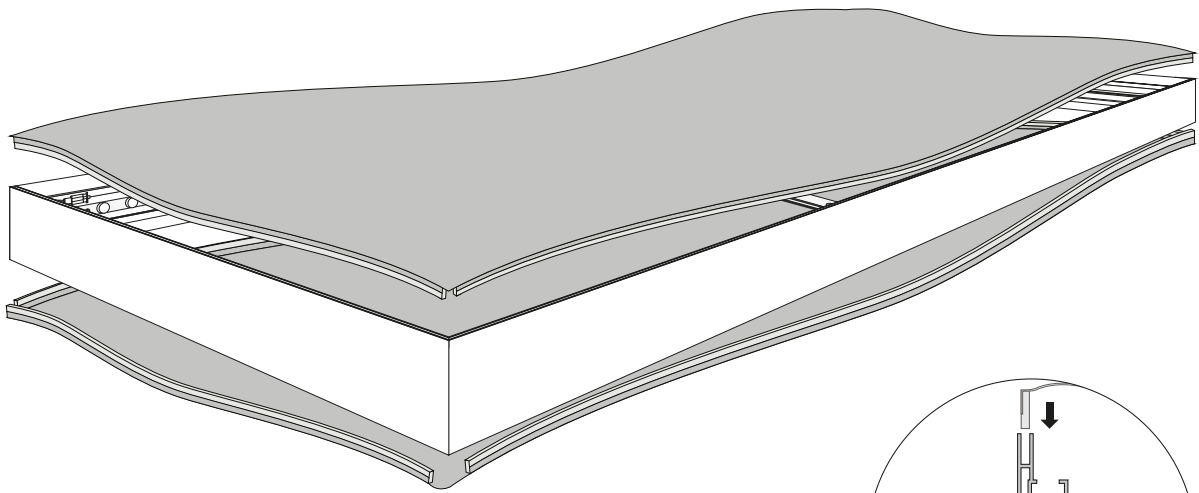
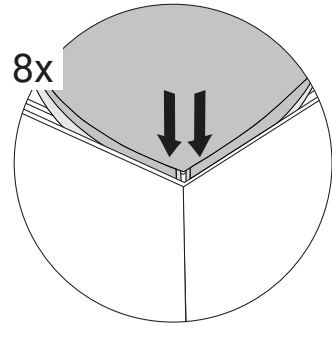
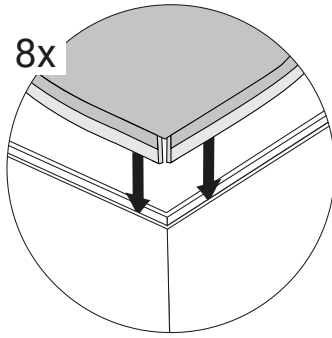
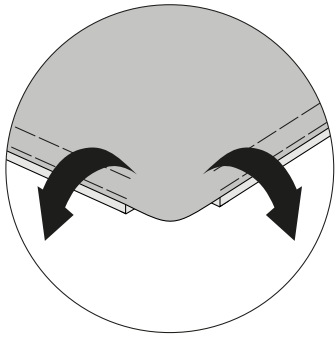

## Fitting printout into the frame manual

### Die Bedienungsanleitung der Drucke auf dem Rahmen

### Instruction de montage des impressions dans le cadre

### Instrukcja zakładania wydruków na ramy

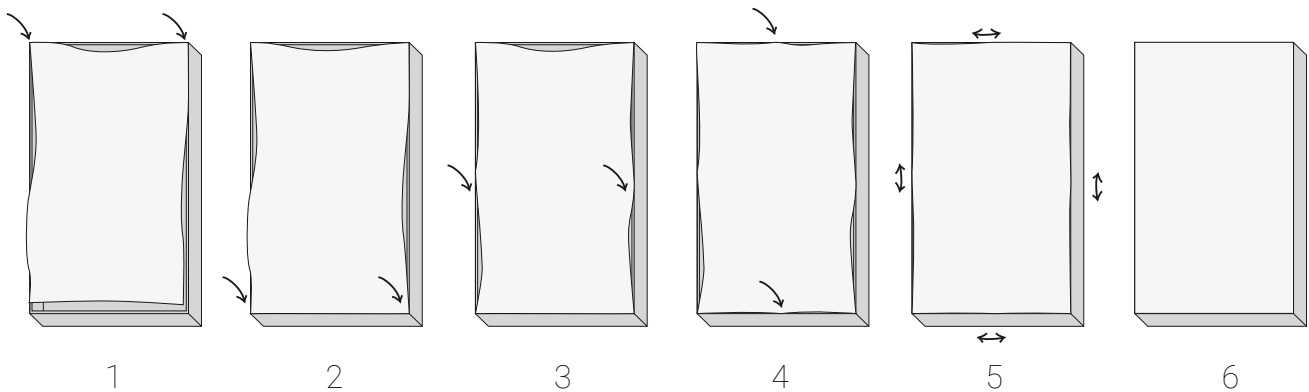

1. First start with two upper corners. Put them inside the frame at the length approx. 10 cm each.  
Zuerst nehmen wir die oberen Ecken über eine Länge ca. 10 cm an.  
Au debut on monte les coins de haut sur la distance de 10 cm environ.  
Na początku zakładamy górne narożniki na długości około 10 cm.
2. Continue with lower ones. Put them inside the frame at the length approx. 10 cm.  
Dann nehmen wir die unteren Ecken über eine Länge ca. 10 cm an.  
Ensuite on monte les coins de bas sur la distance de 10 cm environ.  
Następnie zakładamy dolne narożniki na długości około 10 cm.
3. Place the printout on sides in the middle of the frame.  
Dann nehmen wir die Drucken in der Halberöhe des Rahmens an.  
On glisse le tissu au milieu de cotes plus long.  
Zakładamy wydruki w połowie wysokości ramy.
4. Then fit printout on the top and the bottom of the frame.  
Dann nehmen wir die Drucken in der Halbebweite des Rahmens an.  
On glisse le tissu au milieu de cotes plus court.  
Zakładamy wydruki w połowie szerokości ramy.
5. Afterward put the printout from side to side into the frame starting always from the middle.  
Gleichmäßig von beiden Seiten schieben Sie Druck in Schlitzrahmen (Spalte) ein aber beginnen wir von der Innenlänge und Innenbreite.  
On glisse le tissu dans le cadre en commancant par milieu de chaque cote de cadre vers les coins.  
Równomiernie z dwóch stron wsuwamy wydruk w szczeliny ramy zaczynając od środka długości i szerokości.
6. Caution: printout must be placed accurately (tight) to the frame.  
Fertige Druck soll gleichmäßig über die gesamte Länge des Rahmens angespannt.  
Le tissu monte doit etre tendu uniformement sur tout le cadre.  
Gotowy wydruk powinien być równomiernie napięty na całości ramy.

#### Caution!

Prints need to be handled carefully! Please follow the instruction!

#### Achtung!

Vorsicht mit Druck! Beachten Sie die Bedienungsleitung!

#### Attantion!

Soyez prudent avec l'impression! Suivez les instructions!

#### Uwaga!

Obchodzić się ostrożnie z wydrukami! Postępować zgodnie z instrukcją!